



ErgoMover Manipulator

The ErgoMover Manipulator is a unique self-propelled plate trolley which, besides being able to set down stacks of plasterboards on trestles, can also raise a stack of plasterboards to the vertical position.

Boards up to 3.000 mm can be set down on an ErgoLoader, so the ErgoMover is free to pick up another stack or the stack can be left on the ErgoMover and be mounted on the wall individually with the ErgoMounter.

The ErgoMover Manipulator, Ergoloader and ErgoMounter are three unique units that together form a system for efficiently transporting whole stacks of plasterboard all the way from the truck to the wall without at any time requiring manual lifting of a single board.



ErgoMover Manipulator

SPECIFICATIONS*

Lifting capacity when driving:	1.200 kg
Lifting capacity when tilting:	1.100 kg
Transport of plates up to:	3.000 mm
Length, table:	1.635 mm
Total length w. handle down:	3.671 mm
Width:	701 mm
Height, Min / Max:	590 / 786 mm
Weight:	457 kg
Turning radius:	~ 3,5 m
Voltage:	24 Volt
Speed:	0-6 km/h

! Min. trestle height: 660 mm.

SAFETY

All lifting and tilting functions are done by a powerful electric hydraulic system with built-in safety features.

The ErgoMover Manipulator has been developed in collaboration with professional users and meets all requirements for safe and reliable operation.

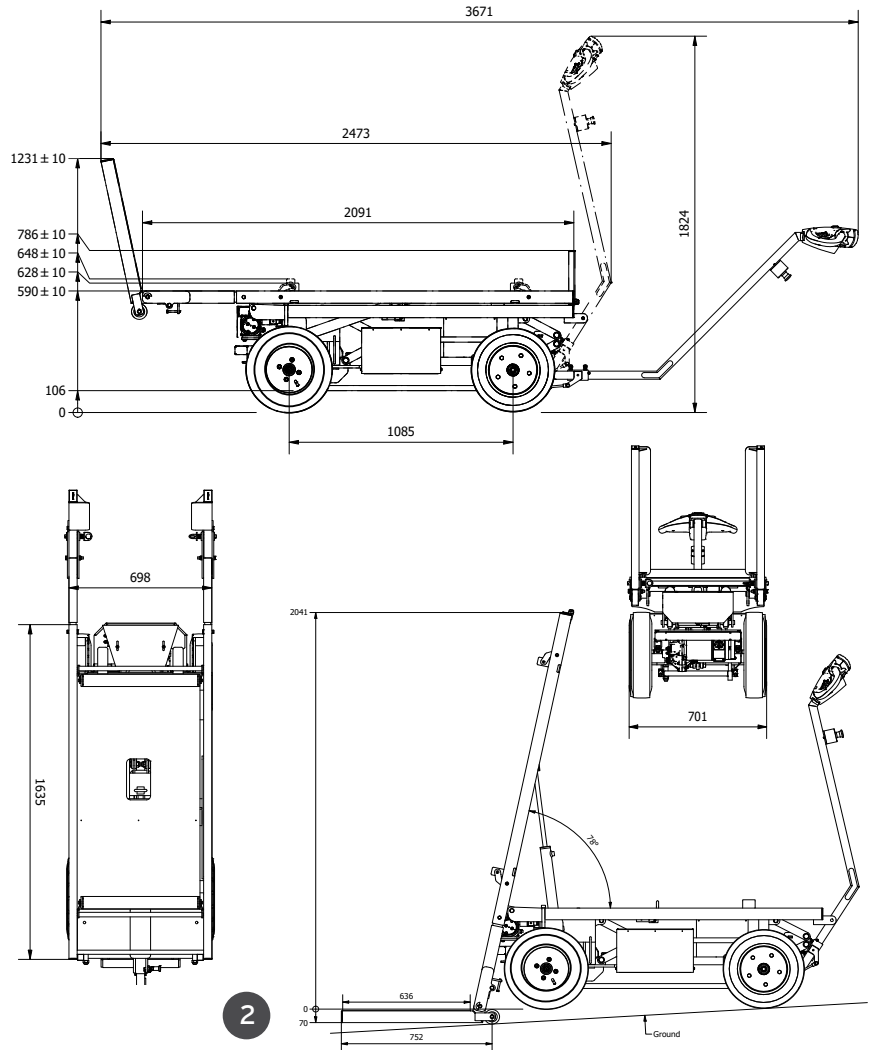

1

ERGOLOADER

The ErgoLoader - the efficient mobile plate rack with wheels that can receive an ENTIRE pallet of plasterboard (42 sheets) in the upright position directly from the ErgoMover Manipulator. The plasterboards are then stores on the ErgoLoader until they are to be mounted onto the wall. Hereby they take up a minimum of floor space. The ErgoLoader are safely and easily handled by one person.

The ErgoLoader comes with two sets of forks:

- Long forks for a full pallet of plasterboards (42 sheets)
- Short forks for half pallets (21 sheets)

When the short forks are mounted, the ErgoLoader can pass through a door opening with half a pallet of plasterboard.

*The dimensions are indicative and may vary +/- 10mm

GMV A/S | www.ergomover.dk

2

ERGOMOUNTER

The ErgoMounter is a unique plasterboard mounting trolley for ergonomic and efficient fitting of drywalling.

When mounting plasterboard on walls, it is now possible with ErgoMover Manipulator and ErgoMounter, to transport full pallets of plasterboard directly from the crane and raise them to the vertical position for mounting on the wall without any back strain

The ErgoMounter is a flexible tool that can be used for mounting all panel widths and - heights. The unique design means that ErgoMounter can be stored with a plate ready for installation. Large pneumatic wheels for maneuverability - even in often very uneven floors.