



OPTION: Extension, suitable for transport of long loads.

# ErgoMover Go

A powerful transport trolley without hydraulic functions for applications that only require transport of materials. Equipped with all-terrain electric motor and 4-wheelsteering, the trolley is ideal for construction sites.

## DIFFERENT MODELS

The ErgoMover Go is available with several different types of standard flat beds, for example with bearers so that non-palletized goods can be set down on it from a truck-mounted crane.

Other options are a flat bed with lashing eyelets which makes it ideal, for example, for lashing racks, so that glass panels can be transported through narrow passages.





# ErgoMover Go

## SPECIFICATIONS\*

Lifting capacity:	1.500 kg
Transport of plates of up to:	3.000 mm
Length, table:	1.620 mm
Width, table:	698 mm
Total width :	701 mm
Total length w. handle down:	3.021 mm
Total length Wireless:	1.702 mm
Height:	575 mm
Weight, w. drawbar:	290 kg
Weight, Wireless	297 kg
Turning radius	~ 3,5 m
Voltage:	24 Volt
Speed:	0-6 km/h

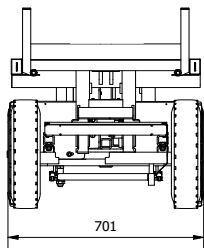
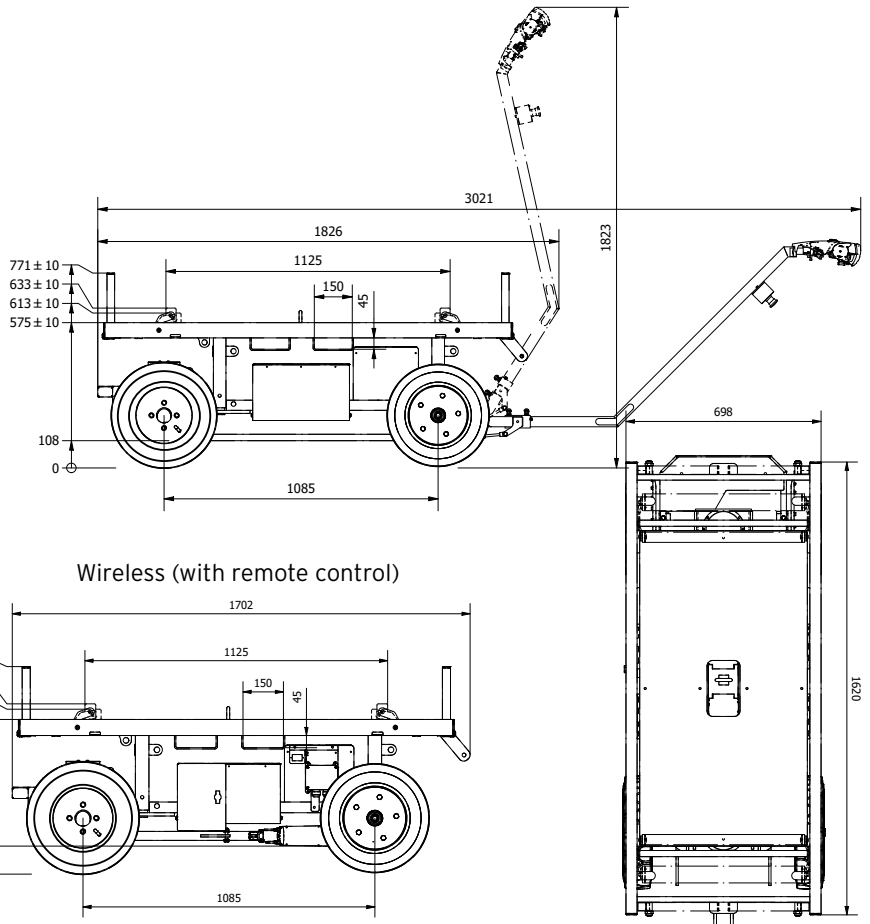

\*The dimensions are indicative and may vary +/- 10mm

## UNIQUE USABILITY AND SAFETY

The ErgoMover Go is equipped with an ergonomic and user-friendly handle with built-in safety functions which lives up to the most strict safety norms. The belly button makes sure the operator is not caught between machine and the wall. Safety device will bring the machine to a complete stop when you let go of the handle. The ErgoMover Go is also equipped with a built-in charger, two joists, four material supports and a parking bracket for the steering handle.

## ALSO AVAILABLE WITH REMOTE CONTROL

ErgoMover Go is available as Wireless, without the drawbar and operator handle. All the functions of the trolley are controlled via radio or cable remote control - depending on which you prefer to use. The Wireless model is particularly suitable for long loads and/or tight spaces.

